

Function

An elongated column of water with impressive vertical effects, the NEF Plume Jet produces an elegant "rooster tail" in gentle winds. Primarily for use in medium-sized and large displays.

Not water level dependent.

Specification

Construction shall be cast bronze with machined inner surface.

Options

ASU Series - 15° swivel connection for directional alignment of nozzle

Notes

1. Requires fine screening at pump for optimum effect (see chart below)
2. Requires flow straightener for optimum effect
3. Contact Crystal Fountains Inc. for detail specification, installation and operation details
4. Contact Crystal Fountains Inc. for customized bore sizes

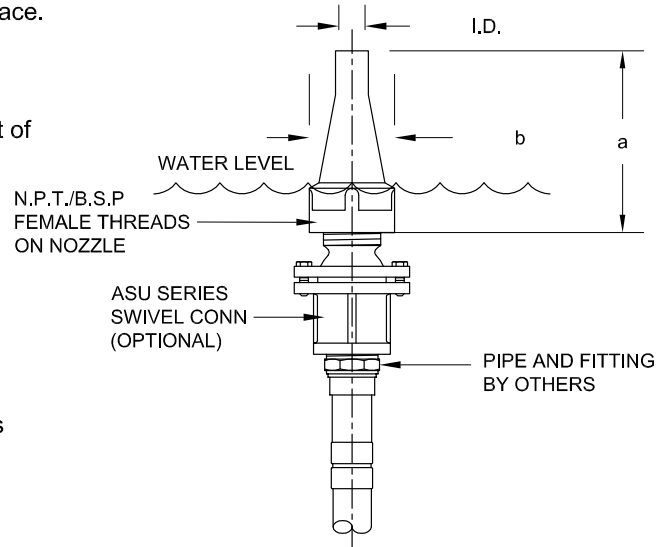

Dimensions

Performance

Part no.	inlet n.p.t. or b.s.p.	suction strainer openings	I.D.	a	b	spray height	Performance															
							5'	10'	15'	20'	30'	40'	50'	60'	70'	80'	90'	100'				
NEF100	1"	.250"	½"	4"	2"	gpm head spread	12 7' 1'	16 13' 1'	21 19' 3'	23 24' 3'												
NEF150	1½"	.300"	⅝"	5"	2½"	gpm head spread		34 14' 1.7'	35 20' 3.3'	38 24' 3.8'	46 42' 5'											
NEF200	2"	.350"	⅞"	6"	3"	gpm head spread		41 14' 2.7'	61 21' 4.3'	70 28' 4.8'	90 40' 6'	113 61' 7'										
NEF300	3"	.500"	1⅝"	10"	4"	gpm head		71 12'	78 19'	124 26'	149 42'	172 56'	188 65'	214 81'								
NEF400	4"	.500"	1½"	11"	5"	gpm head				200 24'	272 42'	301 51'	313 56'	382 81'	422 98'	504 134'	575 145'	600 165'				
NEF500	5"	1.000"	2"	14"	6½"	gpm head				410 27'	530 42'	600 55'	650 70'	730 82'	780 97'	840 110'	890 130'	940 150'				